

E96-309

Bailey®
infi 90

Instruction

Digital I/O Slave Module (IMDSM05)

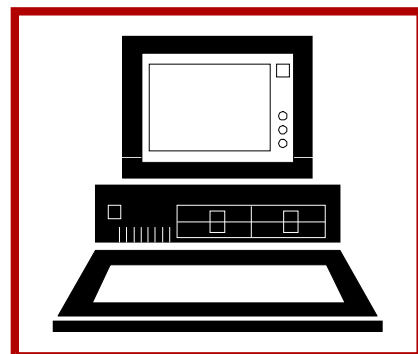
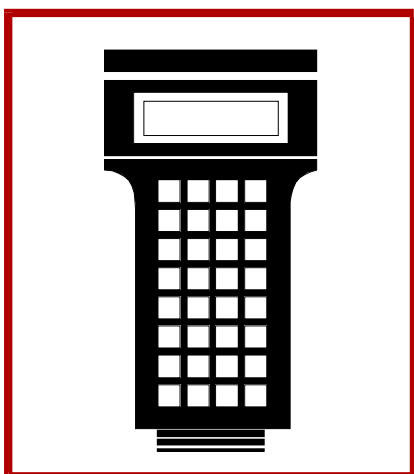
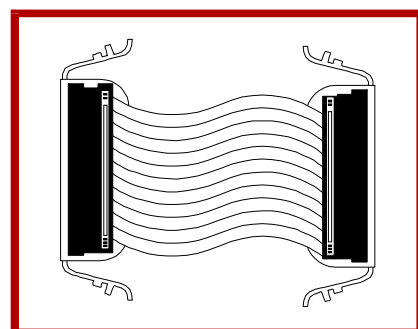
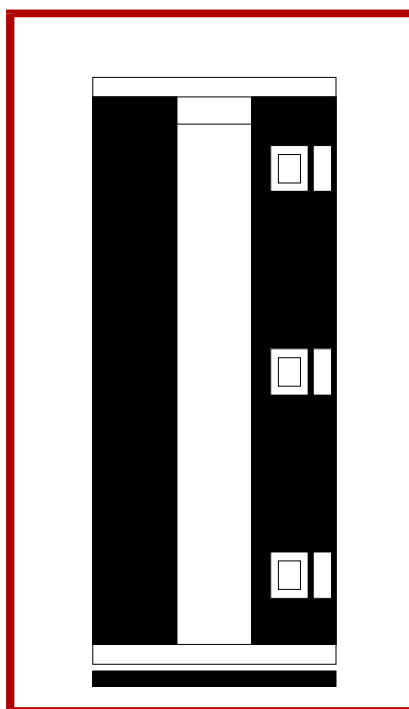
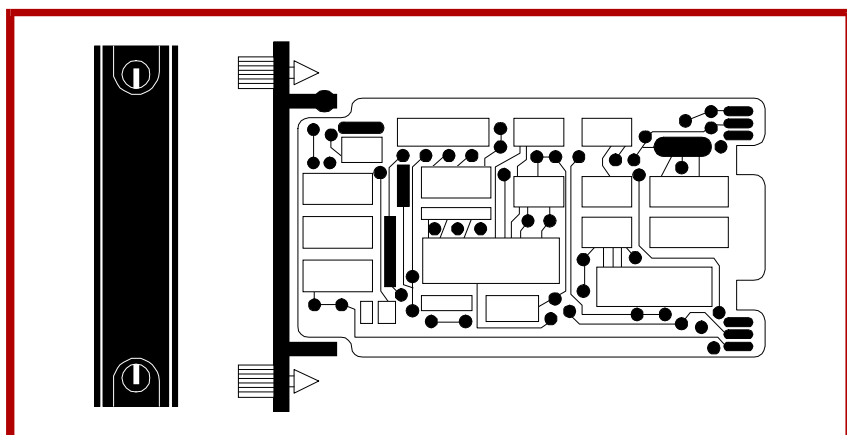
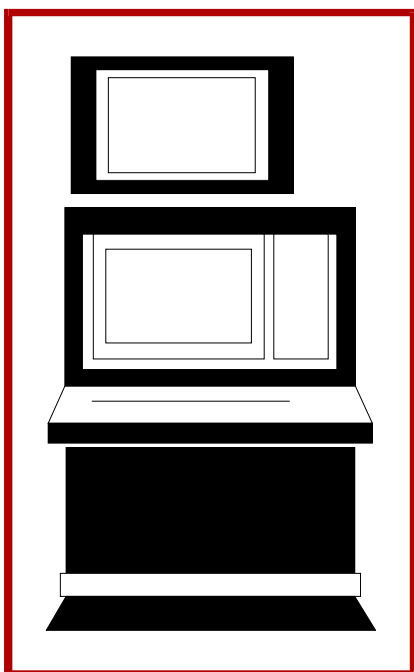

WARNING notices as used in this instruction apply to hazards or unsafe practices that could result in personal injury or death.

CAUTION notices apply to hazards or unsafe practices that could result in property damage.

NOTES highlight procedures and contain information that assists the operator in understanding the information contained in this instruction.

WARNING

INSTRUCTION MANUALS

DO NOT INSTALL, MAINTAIN, OR OPERATE THIS EQUIPMENT WITHOUT READING, UNDERSTANDING, AND FOLLOWING THE PROPER **Elsag Bailey** INSTRUCTIONS AND MANUALS; OTHERWISE, INJURY OR DAMAGE MAY RESULT.

RADIO FREQUENCY INTERFERENCE

MOST ELECTRONIC EQUIPMENT IS INFLUENCED BY RADIO FREQUENCY INTERFERENCE (RFI). CAUTION SHOULD BE EXERCISED WITH REGARD TO THE USE OF PORTABLE COMMUNICATIONS EQUIPMENT IN THE AREA AROUND SUCH EQUIPMENT. PRUDENT PRACTICE DICTATES THAT SIGNS SHOULD BE POSTED IN THE VICINITY OF THE EQUIPMENT CAUTIONING AGAINST THE USE OF PORTABLE COMMUNICATIONS EQUIPMENT.

POSSIBLE PROCESS UPSETS

MAINTENANCE MUST BE PERFORMED ONLY BY QUALIFIED PERSONNEL AND ONLY AFTER SECURING EQUIPMENT CONTROLLED BY THIS PRODUCT. ADJUSTING OR REMOVING THIS PRODUCT WHILE IT IS IN THE SYSTEM MAY UPSET THE PROCESS BEING CONTROLLED. SOME PROCESS UPSETS MAY CAUSE INJURY OR DAMAGE.

AVERTISSEMENT

MANUELS D'OPÉRATION

NE PAS METTRE EN PLACE, RÉPARER OU FAIRE FONCTIONNER L'ÉQUIPEMENT SANS AVOIR LU, COMPRIS ET SUIVI LES INSTRUCTIONS RÉGLEMENTAIRES DE **Elsag Bailey**. TOUTE NÉGLIGENCE À CET ÉGARD POURRAIT ÊTRE UNE CAUSE D'ACCIDENT OU DE DÉFAILLANCE DU MATÉRIEL.

PERTURBATIONS PAR FRÉQUENCE RADIO

LA PLUPART DES ÉQUIPEMENTS ÉLECTRONIQUES SONT SENSIBLES AUX PERTURBATIONS PAR FRÉQUENCE RADIO. DES PRÉCAUTIONS DEVRONT ÊTRE PRISES LORS DE L'UTILISATION DU MATÉRIEL DE COMMUNICATION PORTATIF. LA PRUDENCE EXIGE QUE LES PRÉCAUTIONS À PRENDRE DANS CE CAS SOIENT SIGNALÉES AUX ENDROITS VOULUS DANS VOTRE USINE.

PERTURBATIONS DU PROCÉDÉ

L'ENTRETIEN DOIT ÊTRE ASSURÉ PAR UNE PERSONNE QUALIFIÉE EN CONSIDÉRANT L'ASPECT SÉCURITAIRE DES ÉQUIPEMENTS CONTRÔLÉS PAR CE PRODUIT. L'AJUSTEMENT ET/OU L'EXTRACTION DE CE PRODUIT PEUT OCCASIONNER DES À-COUPS AU PROCÉDÉ CONTRÔLE LORSQU'IL EST INSÉRÉ DANS UNE SYSTÈME ACTIF. CES À-COUPS PEUVENT ÉGALEMENT OCCASIONNER DES BLESSURES OU DES DOMMAGES MATÉRIELS.

NOTICE

The information contained in this document is subject to change without notice.

Elsag Bailey, its affiliates, employees, and agents, and the authors and contributors to this publication specifically disclaim all liabilities and warranties, express and implied (including warranties of merchantability and fitness for a particular purpose), for the accuracy, currency, completeness, and/or reliability of the information contained herein and/or for the fitness for any particular use and/or for the performance of any material and/or equipment selected in whole or part with the user of/or in reliance upon information contained herein. Selection of materials and/or equipment is at the sole risk of the user of this publication.

This document contains proprietary information of Elsag Bailey, Elsag Bailey Process Automation, and is issued in strict confidence. Its use, or reproduction for use, for the reverse engineering, development or manufacture of hardware or software described herein is prohibited. No part of this document may be photocopied or reproduced without the prior written consent of Elsag Bailey.

Preface

The Digital Slave Module (IMDSM05) is an interface for up to sixteen digital I/O field signals to the Infi 90 Process Management System. These digital inputs and outputs are used by master modules to monitor and control a process.

The DSM slave module is used with the Multi-Function Processor (MFP) and Logic Master Module (LMM). The input/output circuitry on the DSM allows it to handle signals between Infi 90 MFPs/LMMs and digital devices in the process system. The DSM also handles signals between MFPs/LMMs and Digital Logic Stations (NDLS02).

This modular flexibility suits the DSM to a wide range of applications. The advanced electronic design of the DSM gives the module the capability to handle the increasing throughput demands of process control systems.

This instruction explains the slave module features, specifications and operation. It details the procedures you must follow to set up and install an IMDSM05 module, and explains status indicators that help in system test and diagnosis.

The system engineer or technician should read and understand this instruction before installing and operating the slave module. A complete understanding of the Infi 90 system is beneficial to the user.

List of Effective Pages

Total number of pages in this manual is 43, consisting of the following:

Page No.	Change Date
Preface	Original
List of Effective Pages	Original
iii through vii	Original
1-1 through 1-6	Original
2-1 through 2-4	Original
3-1 through 3-10	Original
4-1	Original
5-1 through 5-2	Original
6-1	Original
7-1	Original
8-1	Original
A-1 through A-5	Original
B-1 through B-2	Original
C-1	Original
D-1 through D-2	Original

When an update is received, insert the latest changed pages and dispose of the superseded pages.

NOTE: On an update page, the changed text or table is indicated by a vertical bar in the outer margin of the page adjacent to the changed area. A changed figure is indicated by a vertical bar in the outer margin next to the figure caption. The date the update was prepared will appear beside the page number.

Safety Summary

**GENERAL
WARNINGS****Equipment Environment**

All components, whether in transportation, operation, or storage must be in a noncorrosive environment.

Electrical Shock Hazard During Maintenance

Disconnect power or take precautions to ensure that contact with energized parts is avoided when servicing.

Special Handling

This module uses Electrostatic Sensitive Devices (ESD).

**SPECIFIC
WARNINGS**

Disconnect power before installing dipshunts for slave modules on the MMU backplane (slave expander bus). Failure to do so could result in severe or fatal shock. (p. 3-9)

**SPECIFIC
CAUTIONS**

Improper dipshunt configuration can short 24 Volts to ground. (p. B-1)

Sommaire de Sécurité

**AVERTISSEMENTS
D'ORDRE
GÉNÉRAL**

Environnement de l'équipement

Ne pas soumettre les composants à une atmosphère corrosive lors du transport, de l'entreposage ou de l'utilisation.

Risques de chocs électriques lors de l'entretien

S'assurer de débrancher l'alimentation ou de prendre les précautions nécessaires à éviter tout contact avec des composants sous tension lors de l'entretien.

Précautions de Manutention

Ce module contient des composants sensibles aux décharges électro-statiques.

**AVERTISSEMENTS
D'ORDRE
SPÉCIFIQUE**

Couper l'alimentation avant d'installer les dipshunts sur la plaque arrière du châssis de montage de modules (MMU). Toute négligence à cet égard constitue un risque de choc pouvant entraîner des blessures graves, voire mortelles. (p. 3-9)

**ATTENTIONS
D'ORDRE
SPÉCIFIQUE**

La configuration inadéquate des dipshunts peut court-circuiter l'alimentation de 24 volts à la terre. (p. B-1)

Table of Contents

	<i>Page</i>
SECTION 1 - INTRODUCTION	1-1
OVERVIEW	1-1
INTENDED USER.....	1-1
MODULE DESCRIPTION	1-1
FEATURES.....	1-2
INSTRUCTION CONTENT	1-3
HOW TO USE THIS MANUAL	1-3
GLOSSARY OF TERMS AND ABBREVIATIONS	1-4
REFERENCE DOCUMENTS.....	1-5
NOMENCLATURE	1-5
SPECIFICATIONS.....	1-5
SECTION 2 - DESCRIPTION AND OPERATION	2-1
INTRODUCTION.....	2-1
INPUTS AND OUTPUTS	2-1
Input Circuit.....	2-2
Input Circuit Description	2-2
Output Circuit Description.....	2-2
Input Circuit Connections	2-2
CONTROL LOGIC	2-3
Point Data Byte For MFP/LMM	2-3
Status Byte.....	2-3
LOGIC POWER.....	2-4
SLAVE EXPANDER BUS.....	2-4
UNIVERSAL SLAVE EXPANDER BUS INTERFACE.....	2-4
SECTION 3 - INSTALLATION	3-1
INTRODUCTION.....	3-1
SPECIAL HANDLING	3-1
UNPACKING AND INSPECTION	3-1
SETUP	3-2
Enable Switch (MFP/LMM).....	3-3
Slave Address Selection Switch (MFP/LMM)	3-3
Module Configuration Switch	3-5
Default Value Switch	3-6
Digital Input/Output Jumpers	3-6
Master Selection Jumpers	3-8
Termination Unit/Module Configuration	3-8
Physical Installation.....	3-9
WIRING CONNECTIONS AND CABLING	3-9
Wiring.....	3-9
Cable Connections	3-10
FUSING.....	3-10
PRE-OPERATING ADJUSTMENTS	3-10

Table of Contents (continued)

	<i>Page</i>
SECTION 4 - OPERATING PROCEDURES.....	4-1
INTRODUCTION	4-1
OPERATOR/INTERFACE	4-1
START-UP.....	4-1
SECTION 5 - TROUBLESHOOTING.....	5-1
INTRODUCTION	5-1
ERROR MESSAGES AND CORRECTIVE ACTION	5-1
MASTER MODULE ERRORS	5-1
MODULE PIN CONNECTIONS	5-2
SECTION 6 - MAINTENANCE.....	6-1
INTRODUCTION	6-1
MAINTENANCE SCHEDULE	6-1
SECTION 7 - REPAIR/REPLACEMENT PROCEDURES.....	7-1
INTRODUCTION	7-1
MODULE REPAIR/REPLACEMENT	7-1
SECTION 8 - SUPPORT SERVICES.....	8-1
INTRODUCTION	8-1
REPLACEMENT PARTS AND ORDERING INFORMATION	8-1
TRAINING.....	8-1
TECHNICAL DOCUMENTATION.....	8-1
APPENDIX A - NTDI01 TERMINATION UNIT CONFIGURATION.....	A-1
INTRODUCTION	A-1
CONFIGURING NTDI01.....	A-1
PREPARING DIPSHUNT XU17.....	A-3
APPENDIX B - NTDO02 TERMINATION UNIT CONFIGURATION.....	B-1
INTRODUCTION	B-1
INSTALLATION	B-1
APPENDIX C - NTLS01 TERMINATION UNIT CONFIGURATION.....	C-1
INTRODUCTION	C-1
INSTALLATION	C-1
APPENDIX D - NIDI01 TERMINATION UNIT CONFIGURATION.....	D-1
INTRODUCTION	D-1
INSTALLATION	D-1

List of Figures

<i>No.</i>	<i>Title</i>	<i>Page</i>
1-1.	Infi 90 Communication Levels	1-2
2-1.	DSM Block Diagram	2-1
2-2.	I/O Circuit	2-3
3-1.	Switches and Jumpers	3-2
3-2.	Address and Enable Switches	3-3
3-3.	Module Configuration Switch	3-5
3-4.	Default Value Switches	3-7
3-5.	Module Jumper Locations	3-7
4-1.	DSM Front Panel	4-1
A-1.	Dipshunts and Terminal Blocks	A-1
A-2.	Dipshunt, Terminal Block, and I/O Point Relationship	A-2
A-3.	Dipshunt XU17	A-3
A-4.	Dipshunt Configurations	A-4
A-5.	Terminal Assignment for NTDI01	A-4
A-6.	Cable Connections for NTDI01	A-5
B-1.	Cable Connections For NTDO02	B-2
B-2.	Terminal Assignments for NTDO02	B-2
C-1.	Cable Connections For NTLS01	C-1
D-1.	Cable Connections For NIDIO1	D-1
D-2.	Terminal Assignments NIDIO1	D-2

List of Tables

<i>No.</i>	<i>Title</i>	<i>Page</i>
3-1.	Address Switch Settings (MFP/LMM)	3-4
3-2.	Jumper Summary	3-8
3-3.	Cable Connections	3-10
5-1.	P1 Power Pin Connections	5-2
5-2.	P2 Slave Expander Bus Connections	5-2
5-3.	P3 I/O Signal Pin Connections	5-2
6-1.	Maintenance Schedule	6-1
A-1.	NTDI01 Configuration Summary	A-2
B-1.	Configuration Summary	B-1
D-1.	NIDIO1 Configuration Summary	D-1

SECTION 1 - INTRODUCTION

OVERVIEW

The Digital Slave Module (IMDSM05) interfaces process field inputs/outputs with the Multi-Function Processor and Logic Master Module in the Infi 90 Process Management System. There are sixteen I/O circuits on the DSM. These circuits may be input or outputs. The DSM brings in sixteen separate digital signals through the DSM I/O circuits to the master modules for processing and monitoring. The DSM sends sixteen separate digital signals through the DSM I/O circuits to process control devices in the field. Digital control devices may be relays, lamps, etc. A contact closure, switch or solenoid is an example of a device that supplies a digital signal. Master modules provide the control functions; slave modules provide I/O to the master modules. The DSM also works with the Multi-Function Controller (MFC) master module.

This manual explains the purpose, operation and maintenance of the Digital Slave Module (DSM). It addresses handling precautions and installation procedures. Figure 1-1 illustrates the Infi 90 communication levels and the position of the DSM within these levels.

INTENDED USER

System engineers and technicians should read this manual before installing and operating the DSM. A module SHOULD NOT be put into operation until this instruction is read and understood. You can refer to the Table of Contents to find specific information after the module is operating.

MODULE DESCRIPTION

The DSM consists of a single printed circuit board that occupies one slot in a Module Mounting Unit (MMU). It monitors eight digital inputs and eight digital outputs. Twelve I/O circuits are isolated from each other; the remaining two pairs share common positive input lines.

Two captive screws on the module faceplate secure it to the MMU. Sixteen front panel LED status indicators (group A and group B) display the input and output status.

The slave module has three card edge connectors for external signals and power (P1, P2 and P3). P1 connects to common (ground) and +5 VDC power (refer to Table 5-1). P2 connects the module to the slave expander bus to communicate with an MFP/LMM master module (refer to Table 5-2). Connector P3

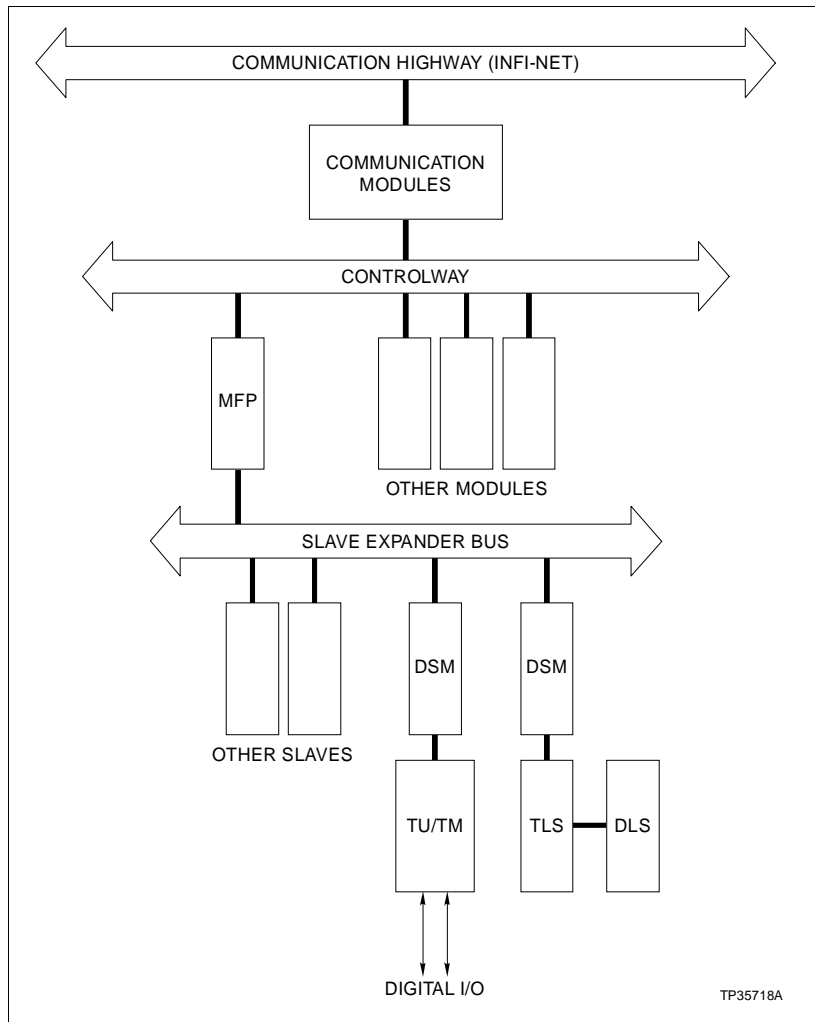

Figure 1-1. Infi 90 Communication Levels

carries digital signals to a Termination Unit (TU) (refer to Table 5-3). The terminal blocks (physical connection points) for field wiring are on the TU.

FEATURES

The modular design of the DSM, as with all Infi 90 modules, allows for flexibility when you are creating a process management system strategy. It is capable of bringing sixteen separate digital signals (24 VDC) into/out of the system.

Multi-Function Processor and Logic Master Module interface to the IMDSM05 on the slave expander bus. The DSM is a high power slave. You can use up to 20 high power slaves on any master (MFP/LMM) slave expander bus.

Individual jumpers on the DSM module configure each of the I/O circuits as inputs/outputs for non-isolated operation with

read-back capabilities, or two-wire isolated outputs without read-back capabilities.

The front panel LED status indicators provide a visual indication of the input states to aid in system test and diagnosis. A DSM can be removed or installed without powering the system down.

INSTRUCTION CONTENT

This manual consists of eight sections.

Introduction	Is an overview of the DSM: Features, description and specifications.
Description and Operation	Explains the module operation and describes the input circuitry.
Installation	Describes precautions to observe when handling DSMs and setup procedures required before module operation. This section also discusses switch and jumper settings, and installation procedures.
Operating Procedures	Explains the front panel indicators and start-up of the slave module.
Troubleshooting	Describes the error indications and corrective actions to take.
Maintenance	Has a maintenance schedule for the slave module.
Repair/Replacement Procedures	Explains how to replace the slave module.
Support Services	Provides replacement part ordering information. It explains other areas of support that Bailey Controls provides.

HOW TO USE THIS MANUAL

Read this manual before handling the DSM module. Refer to the sections in this list as needed for more information.

1. Read **Section 4** before you connect the IMDSM05.
2. Read and do the steps in **Section 3**.
3. Refer to **Section 5** for what to do if a problem occurs.
4. Refer to **Section 6n** for the scheduled steps needed to maintain the DSM.
5. Refer to **Section 7** for how to replace a module.
6. Use **Section 8** for how to order parts. This section also tells you some services Bailey offers.

GLOSSARY OF TERMS AND ABBREVIATIONS

Term	Definition
Configuration	A control strategy with function blocks.
Controlway	A redundant peer-to-peer communication path for point data transfer between intelligent modules within a process control unit.
Digital	A discrete input signal having only two states: on or off.
Dipshunt	Dual in-line package with shorting bars.
Dipswitch	A dual in-line package that contains single pole switches.
EWS	Engineering Work Station; an integrated hardware and software personal computer system for configuring and monitoring Infi 90 modules and systems.
Function Code	An algorithm that defines specific functions. These functions link together to form the control strategy.
LED	Light Emitting Diode; the module front panel indicator that shows status and error messages.
LSB	Least Significant Bit; the bit of a binary number that carries the least numerical weight.
Master Module	One of a series of controller modules designed to direct field processes through a slave module. The multi-function processor is an example.
MFP	Multi-Function Processor Module; a multiple-loop controller with data acquisition and information processing capabilities.
MMU	Module Mounting Unit; a card cage that provides electrical and communication support for Infi 90 modules.
MSB	Most Significant Bit; the bit of a binary number that carries the most numerical weight.
OIS	Operator Interface Station; integrated operator console with data acquisition and reporting capabilities. It provides a window into the process for flexible control and monitoring.
PCU	Process Control Unit; rack type industrial cabinet that contains master, slave and communication modules, and their communication paths.
Slave Expander Bus	Parallel address/data bus between the master module and the slave.
TM	Termination Module: Provides input/output connection between plant equipment and the Infi 90 process modules. The termination module slides into a slot in the termination mounting unit.
TU	Termination Unit: Provides input/output connection between plant equipment and the Infi 90 process modules. The termination unit is a flat circuit board for panel mounting.

REFERENCE DOCUMENTS

I-E96-201	Multi-Function Processor (IMMFP01)
I-E96-202	Multi-Function Processor (IMMFP02)
I-E96-209	Logic Master Module (IMLMM02)
I-E93-911	Termination Unit Manual
I-E96-110	Operator Interface Station
I-E93-916	Engineering Work Station
I-E92-501-2	Configuration and Tuning Terminal
I-E93-900-20	Function Code Application Manual

NOMENCLATURE

The following modules and equipment can be used with a DSM:

IMMFP01/02	Multi-Function Processor Module
IMLMM02	Logic Master Module
NDLS02	Digital Logic Station
NIDI01	Termination Module, Digital Inputs\Outputs
NTDIO	Termination Unit, Digital Inputs\Outputs
NTDO02	Termination Unit, Digital Outputs
NTLS01	Termination Unit, Digital Logic Station
NKTM01	Cable, Termination Module
NKTU02	Cable, Termination Module
NKTU01	Cable, Termination Unit

SPECIFICATIONS

Power Supply	± 5 VDC Logic Supply $\pm 5\%$ ± 24 VDC I/O Supply 21.6 VDC to 27.0 VDC
Current Consumption	5 VDC: 757 mA typical 867 mA maximum
Dissipation	4.6 Watts (logic) 5.0 Watts (I/O)
Inputs	
24 V Logic High Level Input Voltage	V I/O 4.0 Volts minimum
24 V Logic Low Level Input Voltage	V I/O 16.5 Volts maximum
24 V Logic Low Level Input Current	-11.8 mA maximum

SPECIFICATIONS (continued)

Outputs	
24 V Logic Low Level Output Voltage	10 V typical (sink current = 120 mA) 2.0 V maximum
24 V Logic High Level Output Current	100 μ A maximum
24 V maximum Sink Current	120 mA
Propagation Delay Times	
Input	Low to high 50 μ sec. typical High to low 25 μ sec. typical
Output	Low to high 25 μ sec. typical High to low 100 μ sec. typical
Isolation Voltage	150 V RMS Channel to channel 150 V RMS Channel to logic
Surge Withstand	Meets requirements of IEEE Capability Standard 472-1974, on input and output channels.
Maximum Wire Sizes	12 AWG from field wiring to NTDI01
Environmental Specifications	
Ambient Temperature	0 $^{\circ}$ to 70 $^{\circ}$ C (32 $^{\circ}$ to 158 $^{\circ}$ F)
Relative Humidity	0% to 95% up to 55 $^{\circ}$ C (131 $^{\circ}$ F) (non-condensing) 0% to 45% at 70 $^{\circ}$ C (158 $^{\circ}$ F) (non-condensing)
Atmospheric Pressure	Sea level to 3 km. (1.86 miles)
Air Quality	Noncorrosive
Mounting	Uses 1 slot in Infi 90 Module Mounting Unit.
Certification	CSA certified for use as process control equipment in an ordinary (non-hazardous) location.

Specifications subject to change without notice.

SECTION 2 - DESCRIPTION AND OPERATION

INTRODUCTION

This section explains the input and output circuitry, control logic, power and connections for the Digital Slave Module (DSM). The DSM is a digital input/output interface to a Multi-Function Processor (MFP) module or Logic Master Module (LMM). The MFP/LMM support up to 20 DSMs. These modules provide the control functions. The master module communicates with its slave module on a 12-line slave expander bus as shown in Figure 1-1. Each slave on the slave expander bus has a unique address set by the slave address dipswitch (S1) (see Figure 2-1).

The DSM has two identical but independent I/O groups. Each group of eight I/O points (circuits) can operate as inputs or outputs. All points in the group are the same; all are inputs or all are outputs. Each point in the group handles one input or output signal.

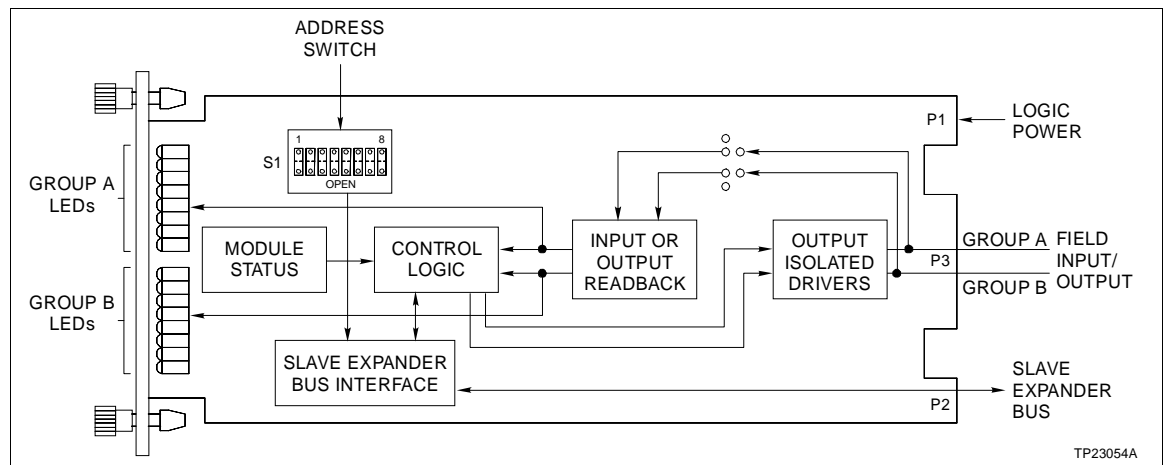

Figure 2-1. DSM Block Diagram

INPUTS AND OUTPUTS

Digital field inputs are 24 VDC. This voltage indicates an energized (ON) field device; a 0 VDC input indicates a de-energized (OFF) field device. Jumpers on the DSM select the outputs for non-isolated or isolated two-wire configuration. Section 3 explains the jumper connections.

NOTE: Due to the number of pins on the P3 connector, twelve inputs/outputs are separate while the remaining two pairs share terminals. The positive (common) side of Point 5 and 6 are tied together in each group and Point 7 and 8 are tied together in each group (refer to Table 5-3). These points must use the same contact voltage (24 VDC). They are not isolated from each other.

Input Circuit

Figure 2-1 shows the DSM block diagram and signal flow through the module. The input isolation block consists of current limiters and optocouplers to isolate the sixteen field inputs (or outputs) from the module circuitry. The input circuits provide 150 VDC isolation between input and logic circuits, and other input channels.

The isolated outputs are sent to a read buffer in the control logic block. If an input is energized, it also causes a corresponding input status LED on the front panel to light.

The control logic block consists of buffers that hold the input and status byte values. The slave expander bus interface allows the master module to read these bytes.

Input Circuit Description

When the DSM uses an I/O point as an input, a signal from the controlling master controls the logic level of the circuit's signal line. This external signal may set the line to logic common (0 VDC) or to logic high (24 VDC). When the input signal is low, current flows through the input circuit. Other circuitry in the DSM senses the current flow, lights the front panel LED that corresponds to the I/O point, and passes a logic 1 to the module. When a signal is high, no current flows through the input circuit. The front panel does not light and a logic 0 passes into the module.

Output Circuit Description

When the DSM uses an I/O point as an output, the module controls the logic level of the signal with a transistor. The transistor energizes to switch the signal line low. The front panel light associated with the I/O point lights and the module outputs a logic 1. When the transistor is not energized, the circuitry sets the signal line high. The front panel LED for the I/O point does not light and the outputs a logic 0.

NOTE: During a power on reset of the DSM such as during installation, before reconfiguration, or after a power outage, the module latches all outputs off if the configuration switch is set to hold values on default. The outputs remain off until a master re-establishes communication with the DSM. The outputs go to preprogrammed default states if both the master module is active and the configuration switch is set to go to the preprogrammed state on default.

Figure 2-2 shows a typical I/O circuit.

Input Circuit Connections

The contact input signals connect to the 30-pin card edge connector P3 (shown in Figure 2-1), using a termination cable from a termination unit or module.

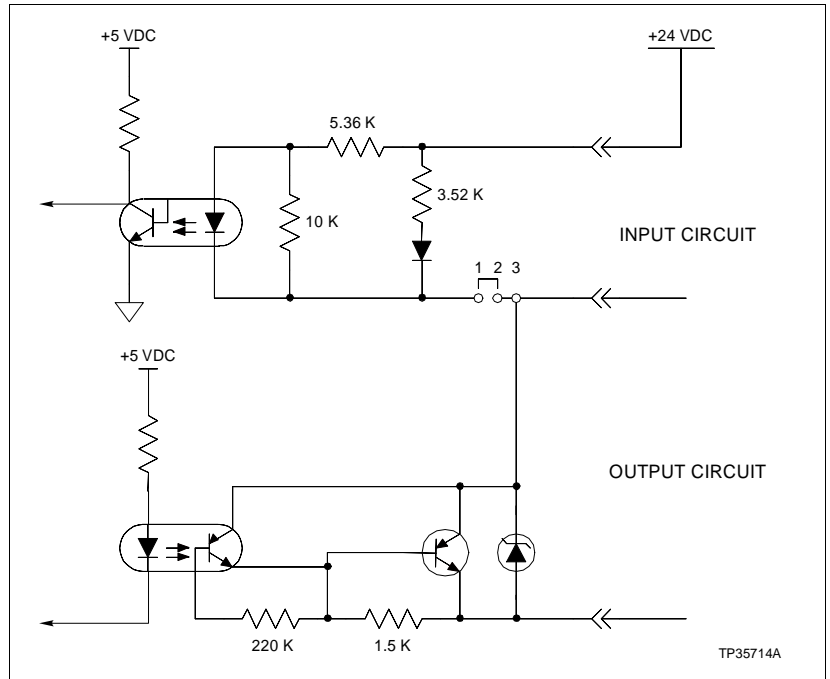

Figure 2-2. I/O Circuit

CONTROL LOGIC

Function Code (FC) 84 in the master module configuration accesses the DSM on the slave expander bus. It also allows the master module to automatically read point (input) data or status data from the DSM. This data is output by the buffer circuits (control logic) to the slave expander bus interface (see Figure 2-1). The slave address in FC 84 must be the same as the address set on the slave address dipswitch (S1).

Point Data Byte For MFP/LMM

The DSM transfers two 8-bit bytes of point data at once to the master module. Each byte corresponds to group A or group B inputs. Each bit of data represents one input. The bit value reflects the state of that input, either open (logic 1) or closed (logic 0). The DSM transfers two 8-bit status bytes at once to the master. One byte for group A and one byte for group B. The MFP or LMM reads the status bytes associated with that group to determine if it will read the data in the point groups set as inputs or write data to the groups set as outputs.

Status Byte

The status byte ensures module integrity and tells the master if the data in the 8-bit data byte is from an input group or an output group. It makes sure slave expander bus communication and master module configuration are correct. The master

module reads the status byte and compares it to an expected value. If a mismatch occurs, it flags the error and marks the point as bad quality.

LOGIC POWER

Logic power (+5 VDC) drives the DSM circuits. It connects through the top 12-pin card edge connector (P1) shown in Figure 2-1.

SLAVE EXPANDER BUS

The Infi 90 slave expander bus is a high speed synchronous parallel bus. It provides a communication path between MFP or LMM master modules and slave modules. The master module provides the control functions and the DSM module provides inputs/outputs to the master module. The P2 card edge connector of the DSM and master module connect to the bus.

The slave expander bus is twelve parallel signal lines located on the Module Mounting Unit (MMU) backplane. A 12-position dipshunt placed in a connection socket on the MMU backplane connects the bus between the master and slave modules. Cable assemblies can extend the bus to six MMUs.

A master module and its slaves form an individual subsystem within a Process Control Unit (PCU). The slave expander bus between master/slave subsystems must be separated. Leaving a dipshunt socket empty or not connecting the MMUs with cables separates them.

UNIVERSAL SLAVE EXPANDER BUS INTERFACE

The DSM uses a semi-custom gate array to perform the slave expander bus interface function. All the control logic and communication protocol are built into an integrated circuit (IC). This IC provides the following functions:

- Address comparison and detection.
- Function code latching and decoding.
- Read strobe generation.
- Data line filtering of bus signals.
- On-board bus drivers.

NOTE: Address information (a single 6-bit module address from the master) enters the DSM through the slave expander bus interface only if the addresses match. Refer to the Installation section for more information.

SECTION 3 - INSTALLATION

INTRODUCTION

This section explains what you must do before you put the Digital Slave Module (IMDSM05) into operation. **DO NOT PROCEED** with operation until you read, understand and do the steps in the order in which they appear.

NOTE: Refer to Product Instruction I-E93-911 for termination device wiring instructions.

SPECIAL HANDLING

NOTE: Always use Bailey's Field Static Kit (P/N 1948385A2 - consists of wrist strap, ground cord assembly, alligator clip) when working with modules. The kit is designed to connect a technician and the static dissipative work surface to the same ground point to prevent damage to the modules by electrostatic discharge.

The Digital Slave Module (DSM) uses electrostatic sensitive devices. Follow Steps 1 through 4 when handling:

1. Keep the module in its special anti-static bag until you are ready to install it in the system. Save the bag for future use.
2. Ground the anti-static bag before opening.
3. Verify that all devices connected to the module are properly grounded before using them.
4. Avoid touching the circuitry when handling the module.

UNPACKING AND INSPECTION

1. Examine the hardware immediately to verify it has not been damaged in transit.
2. Notify the nearest Bailey Controls Sales Office of any damage.
3. File a claim for any damage with the transportation company that handled the shipment.
4. Use the original packing material and container to store the hardware.
5. Store the hardware in an environment of good air quality, free from temperature and moisture extremes.

SETUP

Prior to installation, set the address of the DSM and install jumpers to configure the digital outputs and inputs. Be sure you configure the termination unit (TU) or termination module (TM) to accept the field device signals. Figure 3-1 shows the 5 switches and 18 jumpers to set on the DSM. The module switches and jumpers are:

- An address switch and an enable switch determine the address bytes that precede every data transfer (one module address byte for the MFP/LMM).
- A module configuration switch sets the output to the existing or default value during a communication break with the master.
- Two default value switches set the default value of the A group and B group outputs.
- Two master selection jumpers select a LMM or MFP master for the DSM.
- Sixteen two-position jumpers set outputs for two-wire isolated or normal output operation.

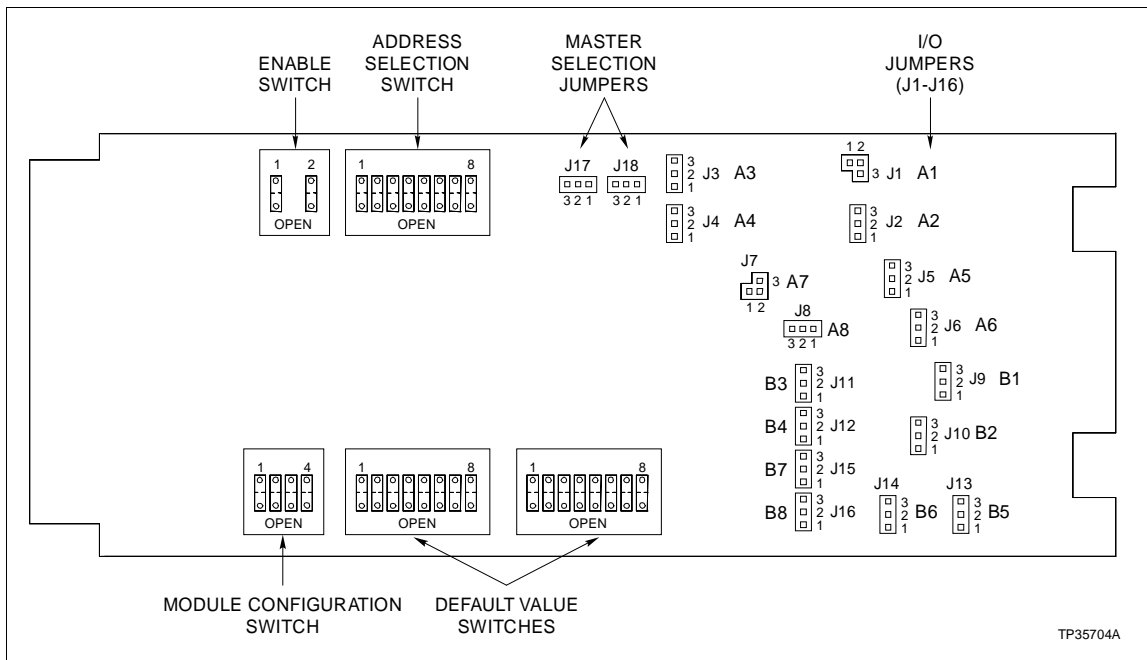

Figure 3-1. Switches and Jumpers

The enable switch allows the DSM to use the address selection switch to set addresses for LMM/MFP operation. The address is set by an eight position address dipswitch shown in Figure 3-2.

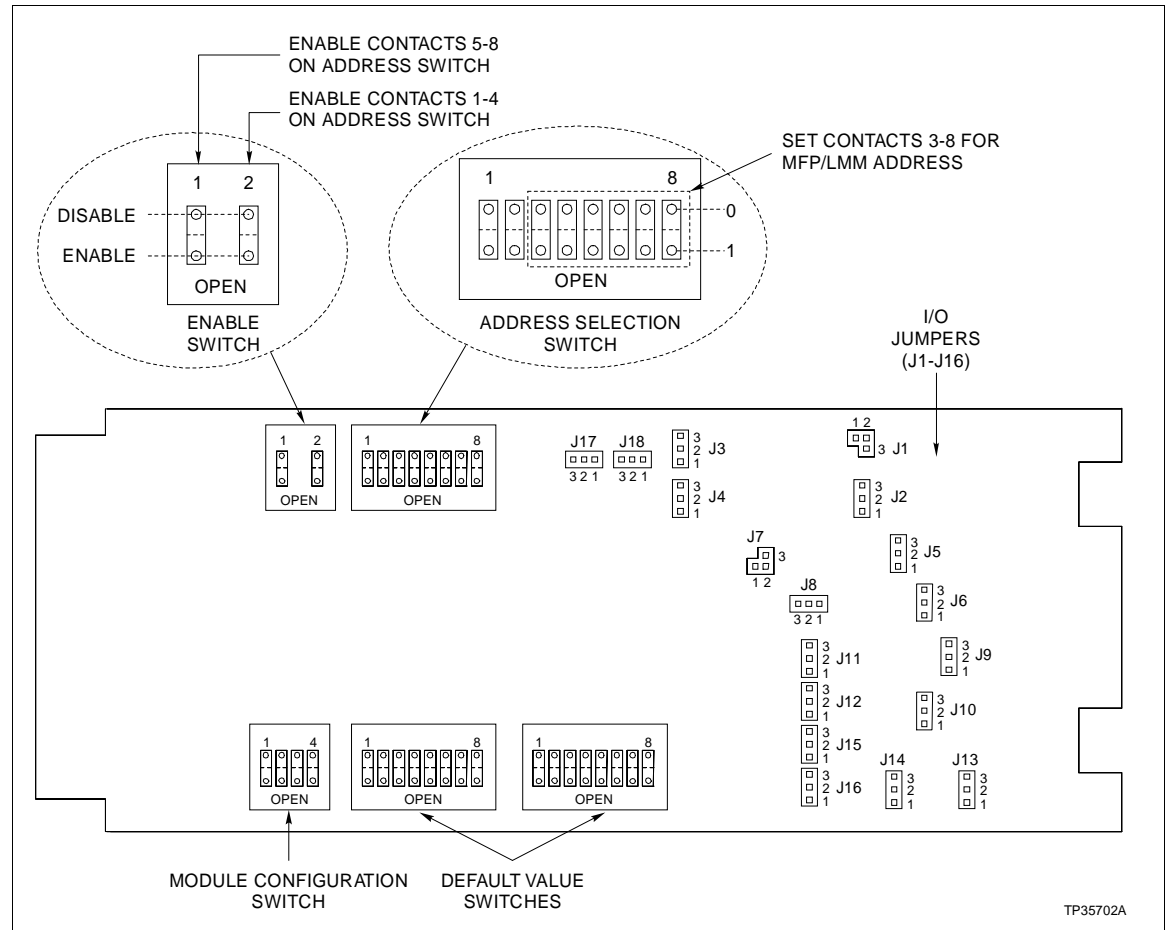

Figure 3-2. Address and Enable Switches

Enable Switch (MFP/LMM)

When the DSM communicates with the MFP, the right contact of the enable switch must be set to the 1 or open position for the module to respond. Set the 6-bit address of the DSM on contacts 3-8 on the address selection switch. Table 3-1 lists the addresses that are possible for each group.

Slave Address Selection Switch (MFP/LMM)

The DSM can have one of 64 addresses (address 0 to 63) on the slave expander bus (20 slaves maximum). This address uniquely identifies the slave to the master module and must be the same as the address set in the master module configuration (Function Code 84 specification 1).

The address is set by an eight position address dipswitch. The six right switch positions (3 through 8) of S1 set the six bit address. Positions 1 and 2 are not used and must remain in the closed position (see Figure 3-2). Table 3-1 is a binary address conversion table for setting the slave address selection switch.

Table 3-1. Address Switch Settings (MFP/LMM)

Addr	MSB						Addr	LSB					
	3	4	5	6	7	8		3	4	5	6	7	8
0	0	0	0	0	0	0	32	1	0	0	0	0	0
1	0	0	0	0	0	1	33	1	0	0	0	0	1
2	0	0	0	0	1	0	34	1	0	0	0	1	0
3	0	0	0	0	1	1	35	1	0	0	0	1	1
4	0	0	0	1	0	0	36	1	0	0	1	0	0
5	0	0	0	1	0	1	37	1	0	0	1	0	1
6	0	0	0	1	1	0	38	1	0	0	1	1	0
7	0	0	0	1	1	1	39	1	0	0	1	1	1
8	0	0	1	0	0	0	40	1	0	1	0	0	0
9	0	0	1	0	0	1	41	1	0	1	0	0	1
10	0	0	1	0	1	0	42	1	0	1	0	1	0
11	0	0	1	0	1	1	43	1	0	1	0	1	1
12	0	0	1	1	0	0	44	1	0	1	1	0	0
13	0	0	1	1	0	1	45	1	0	1	1	0	1
14	0	0	1	1	1	0	46	1	0	1	1	1	0
15	0	0	1	1	1	1	47	1	0	1	1	1	1
16	0	1	0	0	0	0	48	1	1	0	0	0	0
17	0	1	0	0	0	1	49	1	1	0	0	0	1
18	0	1	0	0	1	0	50	1	1	0	0	1	0
19	0	1	0	0	1	1	51	1	1	0	0	1	1
20	0	1	0	1	0	0	52	1	1	0	1	0	0
21	0	1	0	1	0	1	53	1	1	0	1	0	1
22	0	1	0	1	1	0	54	1	1	0	1	1	0
23	0	1	0	1	1	1	55	1	1	0	1	1	1
24	0	1	1	0	0	0	56	1	1	1	0	0	0
25	0	1	1	0	0	1	57	1	1	1	0	0	1
26	0	1	1	0	1	0	58	1	1	1	0	1	0
27	0	1	1	0	1	1	59	1	1	1	0	1	1
28	0	1	1	1	0	0	60	1	1	1	1	0	0
29	0	1	1	1	0	1	61	1	1	1	1	0	1
30	0	1	1	1	1	0	62	1	1	1	1	1	0
31	0	1	1	1	1	1	63	1	1	1	1	1	1

Module Configuration Switch

The module configuration switch shown in Figure 3-3 contains four contacts. These contacts:

- Allow the DSM to interface with a master and field devices.
- Allow the DSM to interface with a Digital Logic Station.
- Set the operation (input or output) of each point group within the I/O circuitry.
- Set the operation of each point group during default.

Contact 3 of the module configuration switch determines the unit to which the module interfaces. If the module is an I/O interface between a master and field devices (such as pushbuttons or relays), then the contact must be in the 0 or closed position. If the module is to interface between a master

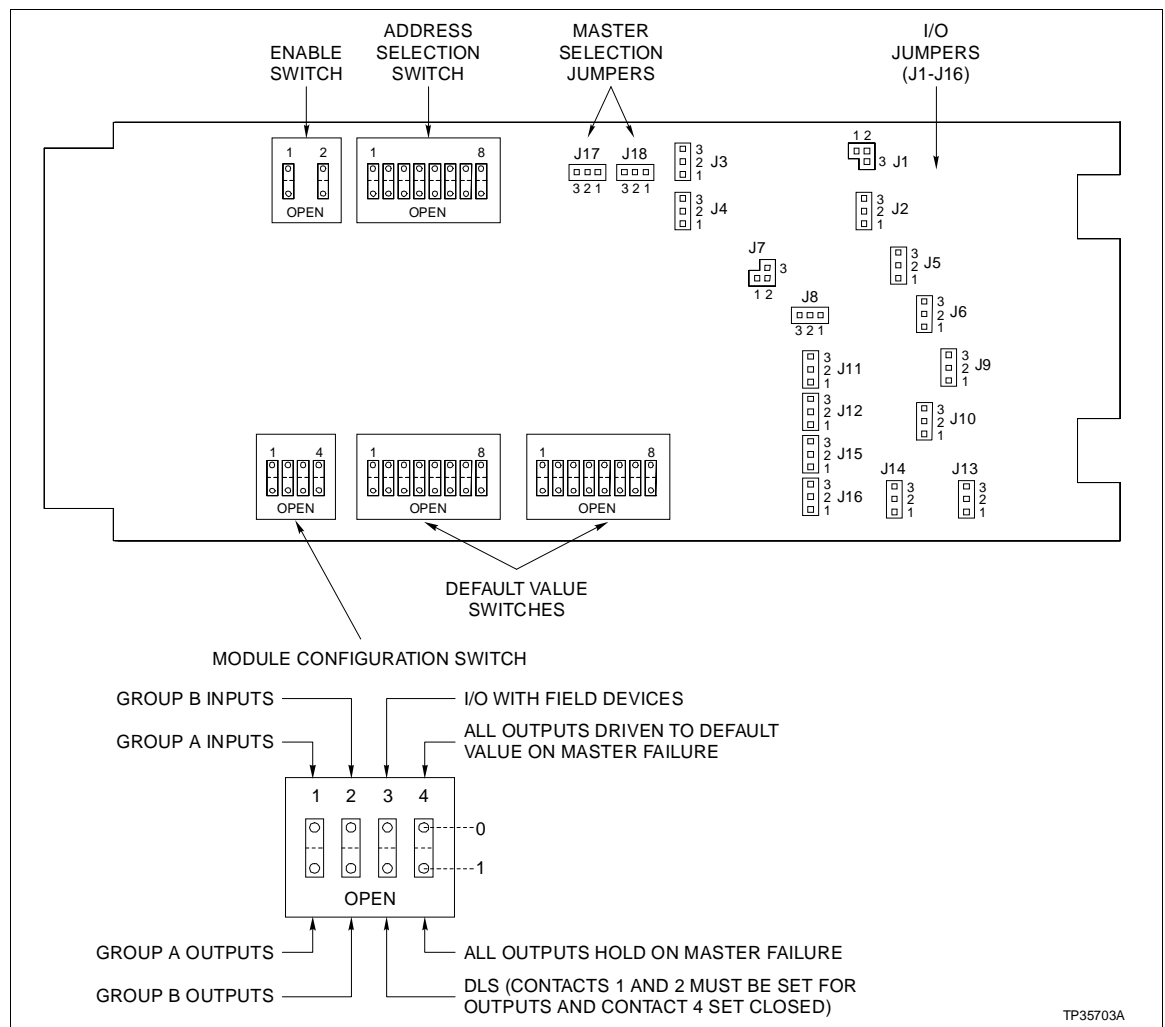

Figure 3-3. Module Configuration Switch

and a Digital Logic Station (DLS), then the contact must be in the 1 or open position. In either of these applications, the first two contacts (1 and 2) of the configuration switch set the operation of two separate point groups in the I/O circuitry. Contact 1 sets the operation of group A. Contact 2 sets the operation of group B. To set these groups for input, set these contacts to the 0 or closed position. To set groups A and B for output, set contacts 1 and 2 to the 1 or open position.

NOTE: When the DSM interfaces between an LMM or an MFP and field devices, you can set these contacts to make the I/O point groups either input or output. When the DSM interfaces between a master and a Digital Logic Station, both point groups must be outputs (contact 1 and 2 must be in the 1 or open position).

Contact 4 on the configuration switch defines the values of output signals during default. This contact allows the DSM to set the operation of the output points if communication to a master is lost. Set contact 4 to the 0 or closed position to drive all outputs to the preset default values. Set contact 4 to the 1 or open position to freeze all outputs when communication is lost.

NOTE: When the DSM interfaces between a master and a Digital Logic Station, contact 4 must be in the 0 or closed position to drive all outputs to the preset levels.

Default Value Switch

Figure 3-4 shows the default value switches. If communication to either master is lost, the DSM will output default values (if contact 4 of the configuration switch is closed). Switch A defines the default value of point group A. Switch B defines the default value of point group B. Each of the eight contacts in the switch set to 1 or open causes an output signal to be sent to the related I/O point during default.

NOTE: When the DSM interfaces between an LMM or an MFP and field devices, you can set these contacts to either open or closed. When the DSM interfaces between a master and a Digital Logic Station, contact 8 of switch B must be set to the 0 or closed position.

Digital Input/Output Jumpers

Each of the I/O points has a removable jumper (J1-J16), see Figure 3-5. Connect this jumper between two of the three posts for each input or output point. To select an I/O point for input, place the jumper between posts 1 and 2. For outputs, place the jumper between posts 1 and 2 to cause the DSM to operate normally. Place the jumper between posts 2 and 3, to isolate the outputs from each other and from the inputs. A jumper connected to posts 2 and 3 makes the output a two wire isolated output.

NOTE: When using two-wire isolated output, the front panel LED for the I/O point does not light and the DSM cannot sense the state of the signal line to the I/O point.

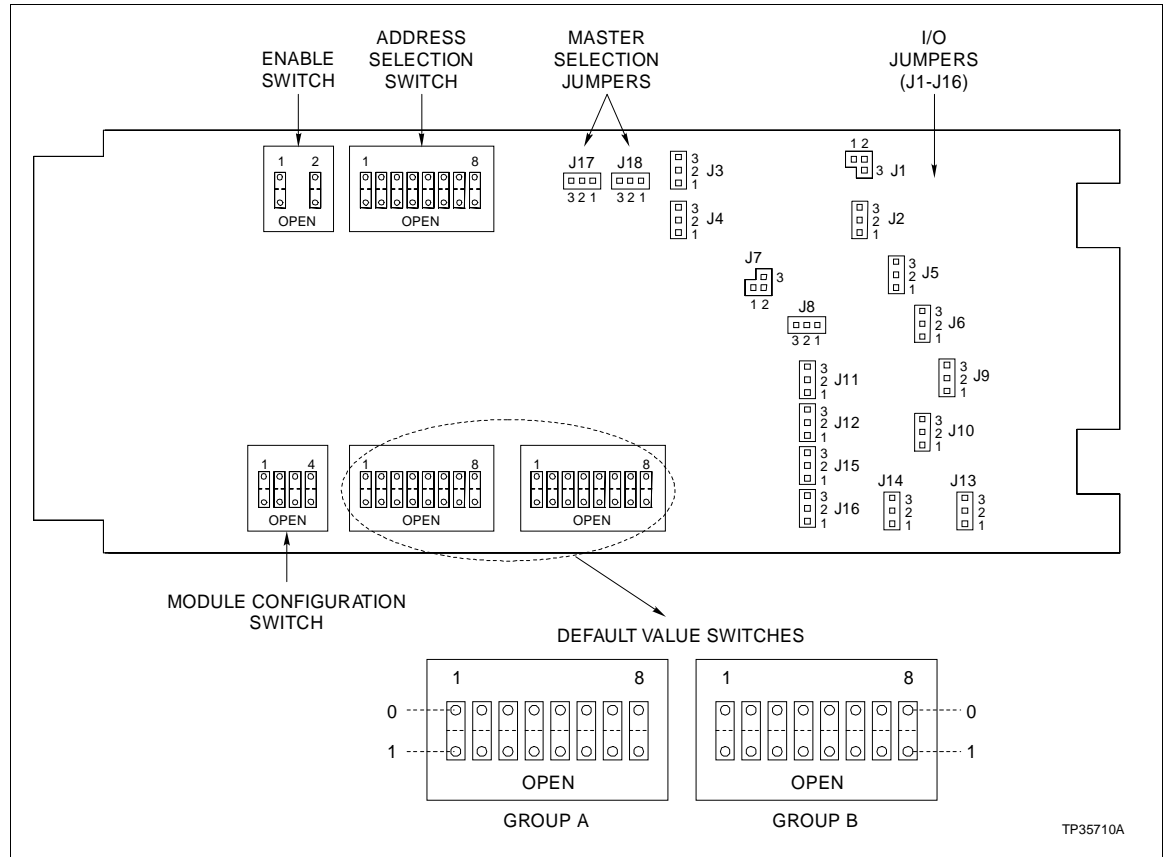

TP35710A

Figure 3-4. Default Value Switches

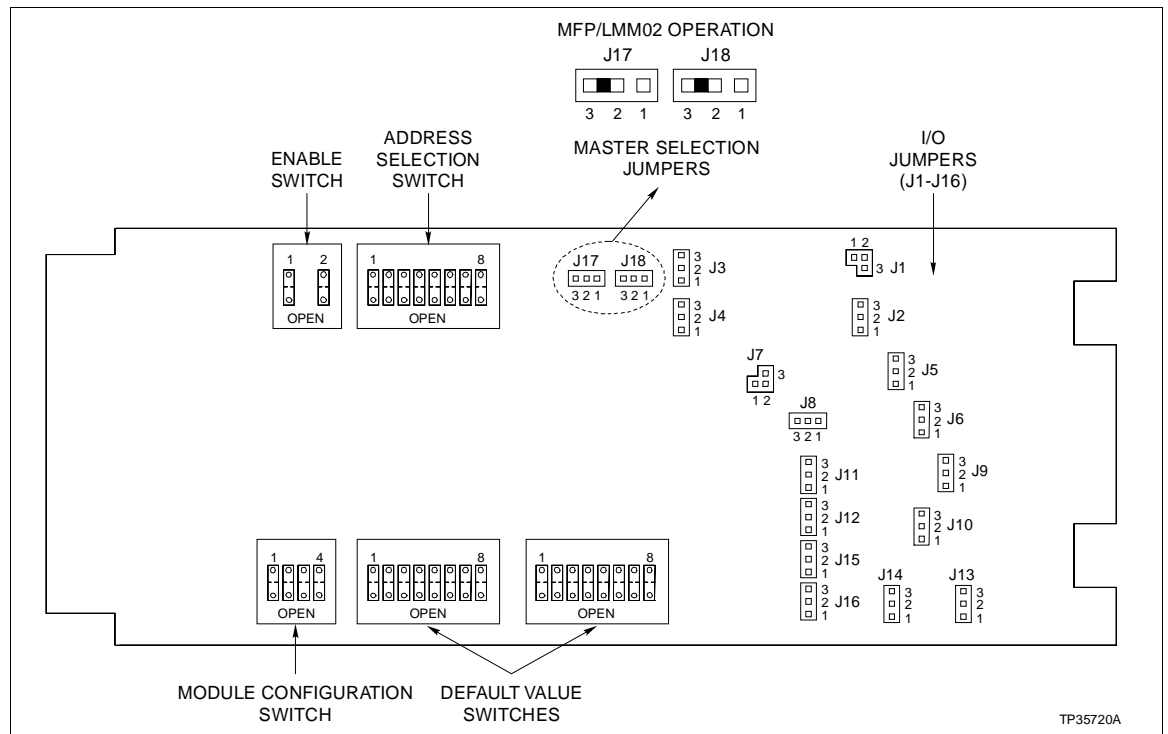

TP35720A

Figure 3-5. Module Jumper Locations

Set the jumpers so they relate to the type of output needed. For common outputs (with an electrically common destination), connect the jumper between posts 1 and 2. For isolated outputs (with no electrically common destination), connect the jumper between posts 2 and 3. Figure 3-5 shows the location of the jumpers on the DSM.

Master Selection Jumpers

The two master selection jumpers on the top of the DSM determine the type of master that the DSM communicates with. Put jumpers J17 and J18 between posts 1 and 2 for the DSM to communicate to an LMM01 master. Put jumpers J17 and J18 between posts 2 and 3 for the DSM to communicate to an MFP, MFC or LMM02 master. See Figure 3-5 for jumper locations.

Table 3-2 summarizes jumper information needed to configure the DSM for installation. It lists the possible applications and I/O jumper placement.

Table 3-2. Jumper Summary

Application	Position of Jumper	Terminal Block Wiring
Input All	Post 1 and 2 (all active I/O Points)	Dry contacts or solid state switches
Output Powering external load	Post 1 and 2 (common output)	Common external load requiring 24 VDC
	Post 2 and 3 (isolated output)	Isolated external load requiring 24 VDC
Sinking external load	Post 1 and 2 (common output)	Common external power source of 24 VDC (one wire from each source to negative post of terminal block)
	Post 2 and 3 (isolated output)	Isolated external power source of 24 VDC (one wire from each source to negative post of terminal block)
Isolated outputs	Posts 2 and 3 (isolated outputs)	User supplies both 24 VDC (to positive post of terminal block) and ground to negative post of terminal block)

Termination Unit/Module Configuration

A TU connects the field device wiring to the Infi 90 system. The terminal blocks (connection points) are located on the TU/TM.

You must configure the TU/TM to accept the digital field inputs sent to the DSM. Refer to the Appendix for your termination unit to determine the configuration for your application.

Physical Installation

NOTE: The Installation section provides instructions pertaining to the physical installation of the slave only. For complete cable and TU/TM information, refer to Termination Unit Manual I-E93-911.

The DSM inserts into a standard Infi 90 Module Mounting Unit (MMU) and occupies one slot. To install:

1. Verify the slot assignment of the module.

WARNING	Disconnect power before installing dipshunts for slave modules on the MMU backplane (slave expander bus). Failure to do so could result in severe or fatal shock.
AVERTISSEMENT	Couper l'alimentation avant d'installer les dipshunts sur la plaque arriere du chassis de montage de modules (MMU). Toute negligence a cet egard constitue un risque de choc pouvant entrainer des blessures graves, voire morelles.

2. Verify that a dipshunt is in the slave expander bus socket on the MMU back plane between the slave and master module.
3. Connect the hooded end of the termination cable from the TU/TM to the MMU back plane. To do this, insert the connector into the back plane slot in the same slot as the one assigned to the slave module. The latches should snap securely into place.
4. Align the module with the plastic guide rails in the MMU; carefully slide the module in until the front panel is flush with the top and bottom of the MMU frame.
5. Tighten the two captive retaining screws on the module faceplate. To remove the module, unscrew the module retaining screws and carefully slide out.

WIRING CONNECTIONS AND CABLING

The DSM has three card edge connectors to supply logic power, establish slave expander bus communication and provide digital inputs (P1, P2, P3 respectively).

Wiring

NOTE: You must install a dipshunt on the back plane of the MMU to connect the slave expander bus between the slave module and master module. Locate the modules so the bus can connect the modules or they will not communicate.

Installing the module in the MMU connects the slave module to the logic power (+5 VDC), necessary to drive the circuitry, at P1. It also connects P2 to the slave expander bus for communication with the master module. P1 and P2 connection require no additional wiring or cabling.

Cable Connections

The DSM uses the NTDI01 and NIDI01 for contact points, NTLS01 for digital logic stations, and NIDO01 for contact output termination. Table 3-3 shows the cables that connect to the DSM. Refer to the appendix listed for more information on your specific application.

Table 3-3. Cable Connections

Cable	Termination Unit	Appendix
NKTU01	NTDI01	Appendix A
NKTU01	NTDO02	Appendix B
NKTU01	NTLS01	Appendix C
NKTU01 or NKTM01	NIDI01	Appendix D

FUSING

The DSM does not have any on board fuses.

PRE-OPERATING ADJUSTMENTS

You do not have to make any adjustments to the DSM before operating.

SECTION 4 - OPERATING PROCEDURES

INTRODUCTION

This section explains the front panel indicators and start-up procedures for the Digital Slave Module (IMDSM05).

OPERATOR/INTERFACE

The DSM module has point (input/output) status LED indicators on the front panel to aid in system test and diagnosis. There are sixteen LEDs divided into two groups of eight (group A and group B). The location of the LEDs is shown in Figure 4-1. Each indicator represents a digital I/O circuit. A red LED indicates an energized I/O point. A blank LED indicates a non-energized I/O point.

START-UP

The DSM start-up is fully automatic. The master module controls the start-up. Function Code (FC) 84 in the configuration of the master module enables the DSM. The address in FC 84 specification 1 must be the same as the address set on the address dipswitch. The front panel LEDs should verify the start-up of the slave (a voltage input must be present to light an LED).

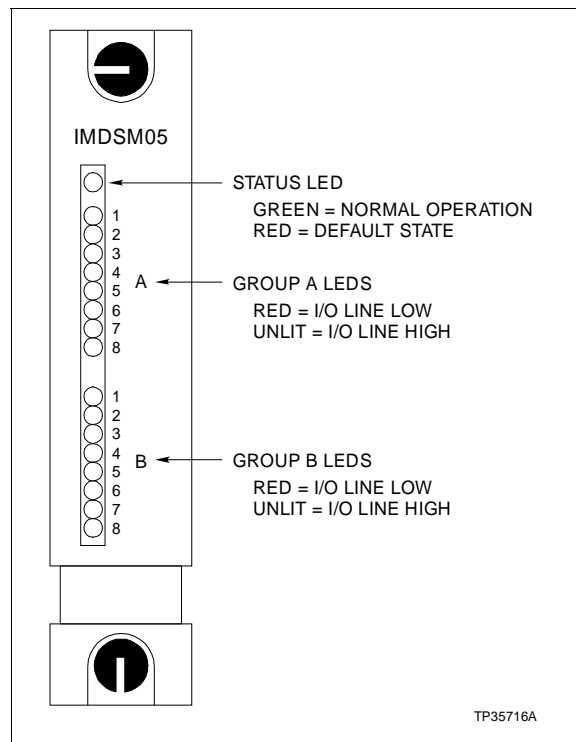

Figure 4-1. DSM Front Panel

SECTION 5 - TROUBLESHOOTING

INTRODUCTION

This section explains the error indications and corrective actions for the Digital Slave Module (IMDSM05).

ERROR MESSAGES AND CORRECTIVE ACTION

You can obtain the status of the DSM by checking the master module for good quality on its input blocks. Use any Infi 90 operator interface (e.g. Operator Interface Station, Engineering Work Station, Configuration and Tuning Terminal) to do this.

NOTE: If you look at the DSM front panel input status LED indicators and none are lit, may indicate a faulty DSM (an input or output must be energized to light an LED). Check the master module for bad quality on its input blocks.

MASTER MODULE ERRORS

The address set on address switch and in the master module configuration must be the same. The master module will generate a MISSING SLAVE MODULE error if they do not match. Verify that the address set on S1 is the same as the address in Function Code (FC) 84 specification 1. If not:

1. Remove the module and change the setting of S1 to correspond with the module configuration (refer to the Installation section for the procedures to set an address and to install a slave module)

OR

2. Modify the address in the module configuration (FC 84 specification 1) to correspond with the address set on S1. Use an Infi 90 operator interface to modify the configuration (for procedures on how to modify a function code specification, refer to the product instruction for the operator interface you are using).

The master module will generate a MISSING SLAVE MODULE error if the slave expander bus is not connected between the slave module and the master module. Verify the bus connection on the MMU back plane.

NOTE: The master module will trip when the DSM module fails if FC 84 specification 3 is set to 0. Changing specification 3 to a 1 will cause the master module to operate when a slave fails.

MODULE PIN CONNECTIONS

The slave module has three connection points for external signals and power (P1, P2 and P3). Tables 5-1, 5-2 and 5-3 show the pin connections.

Table 5-1. P1 Power Pin Connections

Pin(P1)	Connection	Pin(P1)	Connection
1	+5 VDC	7	NC
2	+5 VDC	8	NC
3	NC	9	NC
4	NC	10	NC
5	Power Common	11	NC
6	Power Common	12	NC

NC = Not Connected

Table 5-2. P2 Slave Expander Bus Connections

MFP/LMM Master			
Pin(P2)	Signal	Pin(P2)	Signal
1	Data 1	7	Data 7
2	Data 0	8	Data 6
3	Data 3	9	Clock
4	Data 2	10	Sync
5	Data 5	11	+5V
6	Data 4	12	GND

Table 5-3. P3 I/O Signal Pin Connections

Group A		Group B	
Pin (P3)	Point	Pin (P3)	Point
A	1+	K	1+
1	1-	9	1-
B	2+	L	2+
2	2-	10	2-
C	3+	M	3+
3	3-	11	3-
D	4+	N	4+
4	4-	12	4-
*E ←	5+	*P ←	5+
5 ←	5-	13 ←	5-
E ←	6+	P ←	6+
6	6-	14	6-
*H ←	7+	*S ←	7+
7	7-	15	7-
H ←	8+	S ←	8+
J	8-	8	8-
F	+24V	R	+24V

NOTE: * Shared Pin

SECTION 6 - MAINTENANCE

INTRODUCTION

The Digital Slave Module (IMDSM05) requires limited maintenance. This section contains a maintenance schedule.

MAINTENANCE SCHEDULE

Perform the tasks in Table 6-1 at the specified intervals.

Table 6-1. Maintenance Schedule

Task	Interval
Clean and tighten all power and grounding connections.	Every 6 months or during plant shutdown, whichever occurs first.
Use a static safe vacuum cleaner to remove dust from: Modules Module Mounting Unit Fan Assembly Power Entry Panel	Every 6 months or during plant shutdown, whichever occurs first

SECTION 7 - REPAIR/REPLACEMENT PROCEDURES

INTRODUCTION

This section explains the replacement steps for an Digital Slave Module (IMDSM05). There are no special tools required to change the DSM.

MODULE REPAIR/REPLACEMENT

If you determine the DSM is faulty, replace it with a new one. DO NOT try to repair the module; replacing components may affect the module performance. You can remove the module while system power is supplied.

NOTE: Ensure that the replacement module switch and jumper settings are the same as the original module.

To replace a module:

1. Push and turn the two front panel captive retaining screws one half turn to unlatch the module. It is unlatched when the slots on the screws are vertical and the open end of the slots face away from the module.
2. Gently slide the module out of the MMU.
3. Configure the replacement module switch and jumper settings. Ensure they are set the same as the original module.
4. In the same slot assignment as the original module, align the replacement module with the plastic guide rails in the MMU. Gently slide it in until the front panel is flush with the top and bottom of the MMU frame.
5. Push and turn the two captive retaining screws on the module faceplate one half turn to the latched position. It is latched when the slots on the screws are vertical and the open ends face the center of the module. (To remove the module, turn the module retaining screws to the unlatched position and gently slide out).
6. Return to normal operation.

SECTION 8 - SUPPORT SERVICES

INTRODUCTION

Bailey Controls is ready to help you use, apply and repair its products. Contact your nearest sales office to request services for sales, repair and maintenance contracts. Your sales office can answer your questions on how to apply and install the Bailey Infi 90 system. They can help you apply and install separate devices onto your system if you want to update your process or expand it.

REPLACEMENT PARTS AND ORDERING INFORMATION

When making repairs in your plant, be sure to order parts from a Bailey sales office. If you provide accurate information when ordering parts, it helps us to get the correct parts to you when you need them. Have this information ready when you call in to order parts:

1. Part description, part number and quantity.
2. Model and serial numbers.
3. Bailey instruction manual number, page number and figure that describes the part.

When you order standard parts from Bailey Controls, use part numbers and descriptions from the Recommended Spare Parts Lists. Order parts without commercial descriptions from the nearest Bailey Controls sales office.

TRAINING

Bailey Controls has a modern training complex that provides service and repair instruction. Service and repair training courses can be delivered in your plant to train your service personnel. Contact a Bailey Controls sales office for more information and to schedule training.

TECHNICAL DOCUMENTATION

You can obtain additional copies of this manual from the nearest Bailey sales office at a reasonable charge. The current manuals for all products being offered are can be ordered.

APPENDIX A - NTDI01 TERMINATION UNIT CONFIGURATION

INTRODUCTION

The Digital Slave Module (DSM) uses a NTDI01 to terminate field wiring. Dipshunts on the termination unit configure the digital inputs.

CONFIGURING NTDI01

Figure A-1 shows the dipshunts and terminal blocks on the termination unit. The termination unit has 17 sockets numbered XU1 through XU17. The dipshunts and terminal blocks are divided into group A and group B. Group A dipshunts and terminal blocks control the I/O circuits for group A. Group B dipshunts and terminal blocks control the I/O circuits for group B.

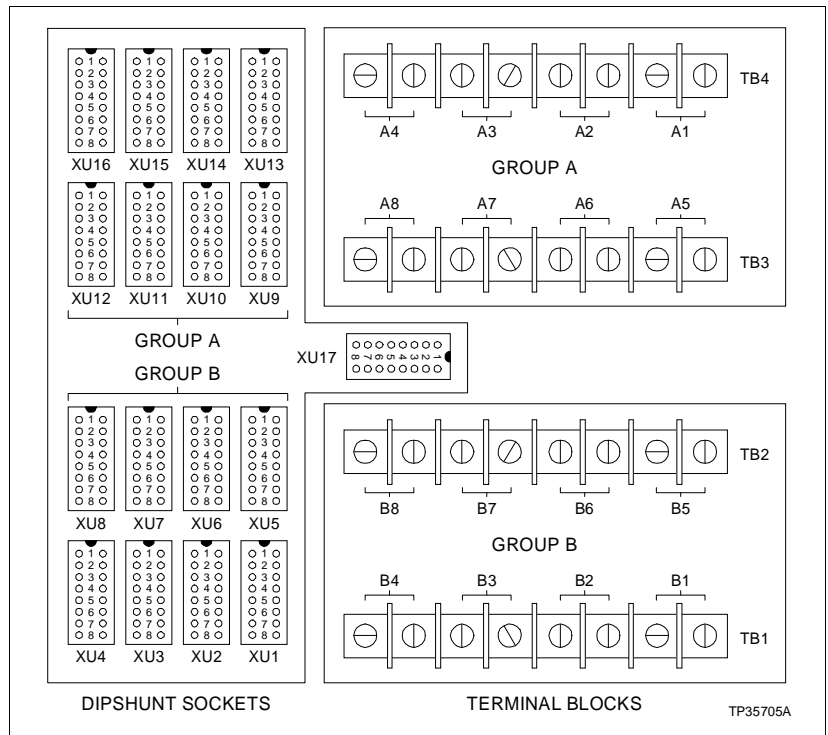

Figure A-1. Dipshunts and Terminal Blocks

Figure A-2 shows the relationship between the dipshunts, terminal blocks and I/O circuits on the DSM. Compare the connections for the posts of terminal block B1 and dipshunt XU1 in group B to the same connections in Figure A-1. Figure A-2 also shows the dipshunt connection to the NKTU01 cable that plugs from the termination unit to B1 on the DSM.

NOTE: The DSM cannot sense the status of the output line for isolated outputs. The front panel light will not light.

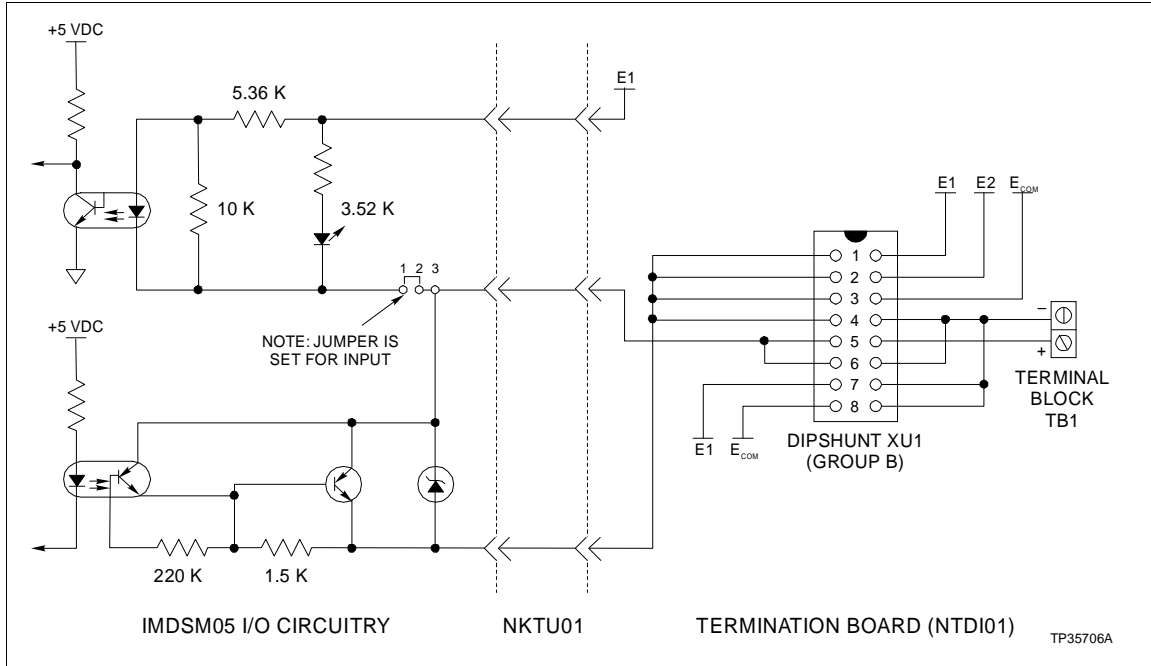

Figure A-2. Dipshunt, Terminal Block, and I/O Point Relationship

Table A-1 summarizes all of the information needed to configure the DSM for installation. It lists the possible applications, dipshunt strapping and terminal block wiring.

Table A-1. NTDI01 Configuration Summary

Application	Dipshunt Configuration	Terminal Block Wiring
Input All	Strap: 3,4,5 Cut: 1,2,6,7,8	Dry contacts or solid state switches
Output Powering external load	Strap: 3,6,7 Cut: 1,2,4,5,8	Common external load requiring 24 VDC
		Isolated external load requiring 24 VDC
Sinking external load	Strap: 3,6 Cut: 1,2,4,5,7,8	Common external power source of 24 VDC (one wire from each source to negative post of terminal block)
		Isolated external power source of 24 VDC (one wire from each source to negative post of terminal block)
Isolated Outputs	Strap: 4,5 Cut: 1,2,3,6,7,8	User supplies both 24 VDC (to positive post of terminal block) and ground to negative post of terminal block)

PREPARING DIPSHUNT XU17

Dipshunt XU17 defines a termination unit specifically for the DSM. Figure A-3 shows the XU17 dipshunt as it applies to DSM applications. All XU17 dipshunts for termination boards that interface the DSM to field devices must be configured as Figure A-3 shows.

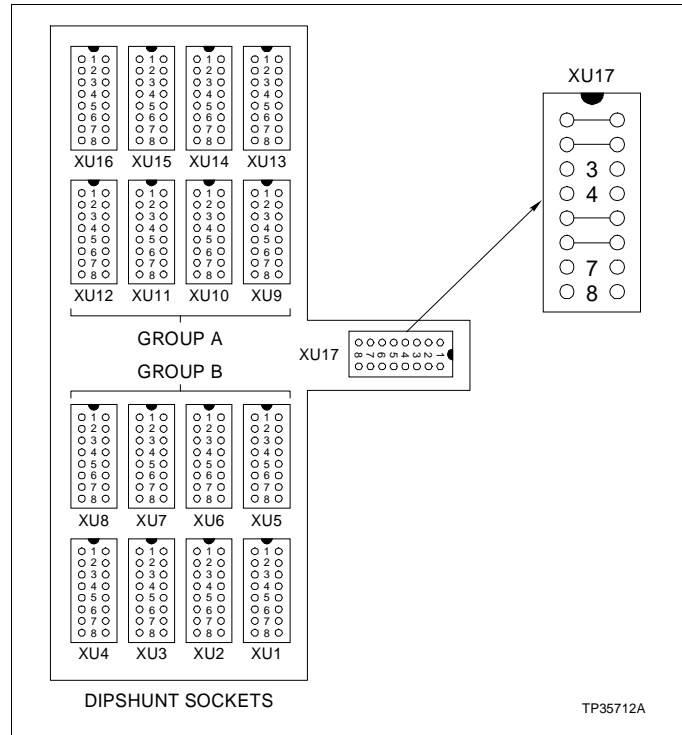

Figure A-3. Dipshunt XU17

Figure A-4 shows dipshunts XU1 through XU16 and XU17 configuration for the possible NTDI01 applications.

Figure A-5 shows the terminal assignments for NTDI01.

Check the switch and jumper settings on the DSM and the dipshunts on the termination unit. Install the DSM and cables as shown in Figure A-6.

Application Signal Type	Dipshunt Configuration XU1 - XU8	Dipshunt Configuration XU17
Dry Contacts or Solid State Switches		
Powering an External Load		
Sinking an External Load		
Isolated Outputs		

Figure A-4. Dipshunt Configurations

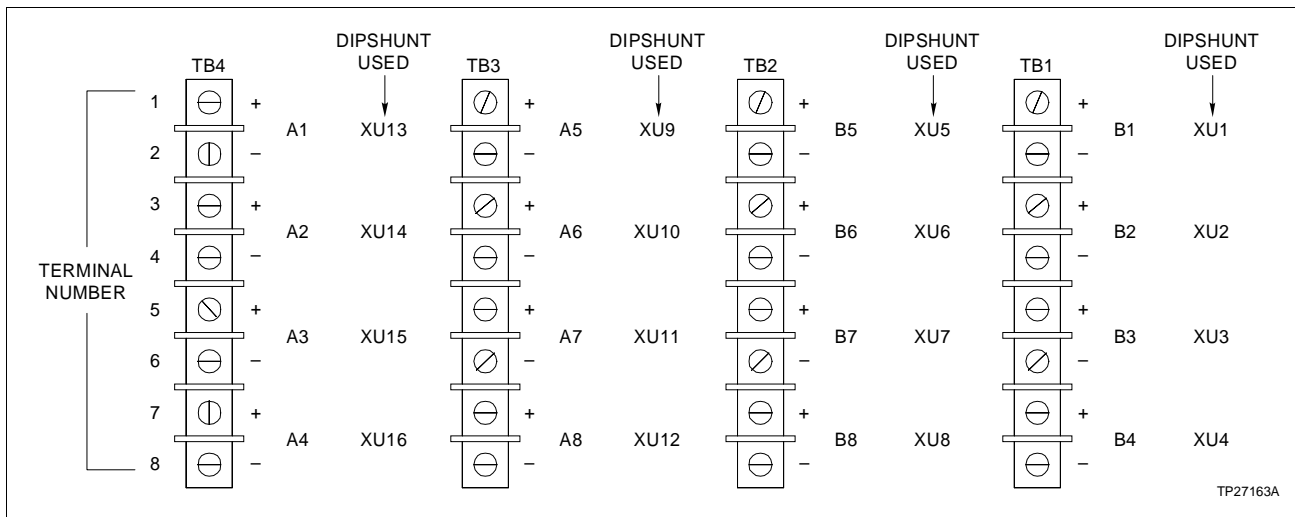

Figure A-5. Terminal Assignment for NTDI01

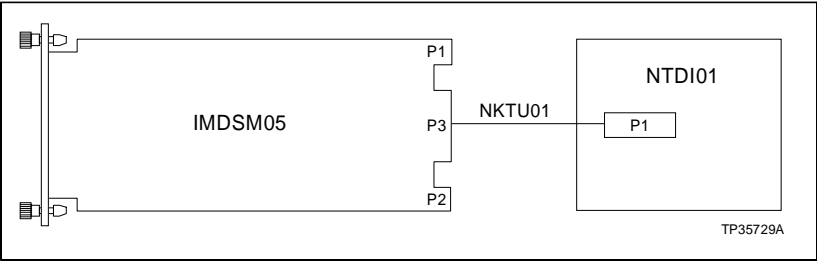

Figure A-6. Cable Connections for NTDI01

APPENDIX B - NTDO02 TERMINATION UNIT CONFIGURATION

INTRODUCTION

The Digital Slave Module (DSM) uses a NTDO02 to terminate field wiring from AC or DC loads. The termination unit provides solid state relays for switching. The termination unit (TU) can be daisy-chained to other TUs with solid state relays. Dipshunts allow the DSM to control any solid state relay with a maximum of 9 per output. For example, 18 termination units can be daisy-chained together by NKDO01 cables and be controlled by one DSM. The NTDO02 is a direct replacement for the NTDO01.

INSTALLATION

Table B-1 shows the dipshunt configuration to interface the NTDO02 to the DSM. The DSM has 16 outputs and requires 2 NTDO02s to interface all the outputs.

Table B-1. Configuration Summary

Application Signal Type	Connecting Cable	Dipshunt Configuration	No. of Outputs
120 VAC 125 VDC 24 VDC	NKTU01		8

NOTES:

1. 1-8 represents strap numbers on the dipshunt where a blank indicates an open strap and a line indicates a closed strap.
2. XU3 - XU10 must be configured identically when connecting two or more termination units in a daisy-chain.

CAUTION	Improper dipshunt configuration can short 24 Volts to ground.
AVERTISSEMENT	La configuration inadéquate des dipshunts peut court-circuiter l'alimentation de 24 volts a la terre.

After setting the switches on the DSM module and setting the jumpers and dipshunts on the termination unit, install the DSM, NTDO02 and cables as shown in Figure B-1.

Figure B-2 shows the terminal assignments for NTDO02.

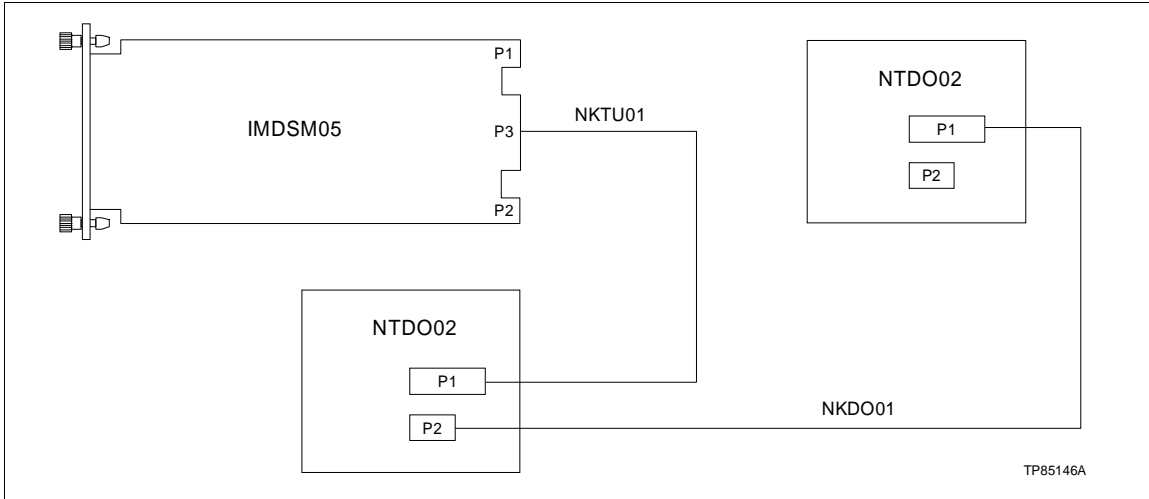

Figure B-1. Cable Connections For NTDO02

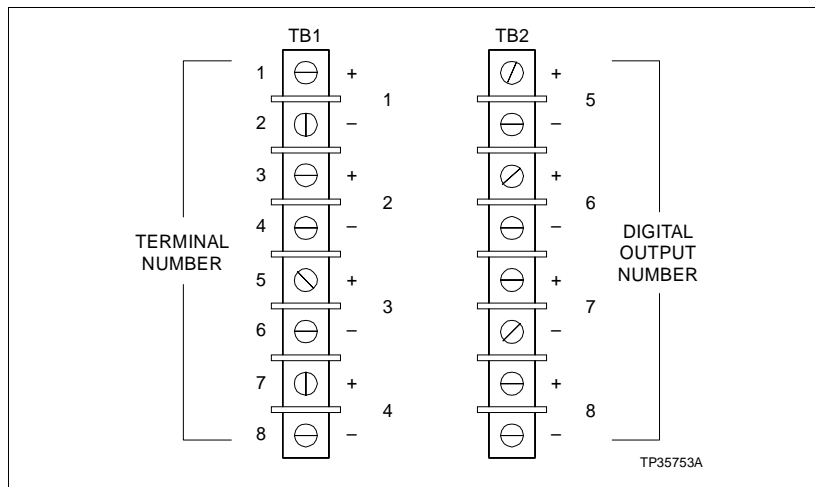

Figure B-2. Terminal Assignments for NTDO02

APPENDIX C - NTLS01 TERMINATION UNIT CONFIGURATION

INTRODUCTION

The NTLS01 termination module interfaces the NDLS02 to the DSM. A single station requires the NKDS01 cable, using edge connection to the station (P1) and plug connection to the termination unit (P2-P5). Multiple stations are connected together using daisy-chain connection cables (NKDS05). The lead station is connected to the termination unit using the NKDS04 cable.

INSTALLATION

Figure C-1 shows the cable connections for the NTLS01.

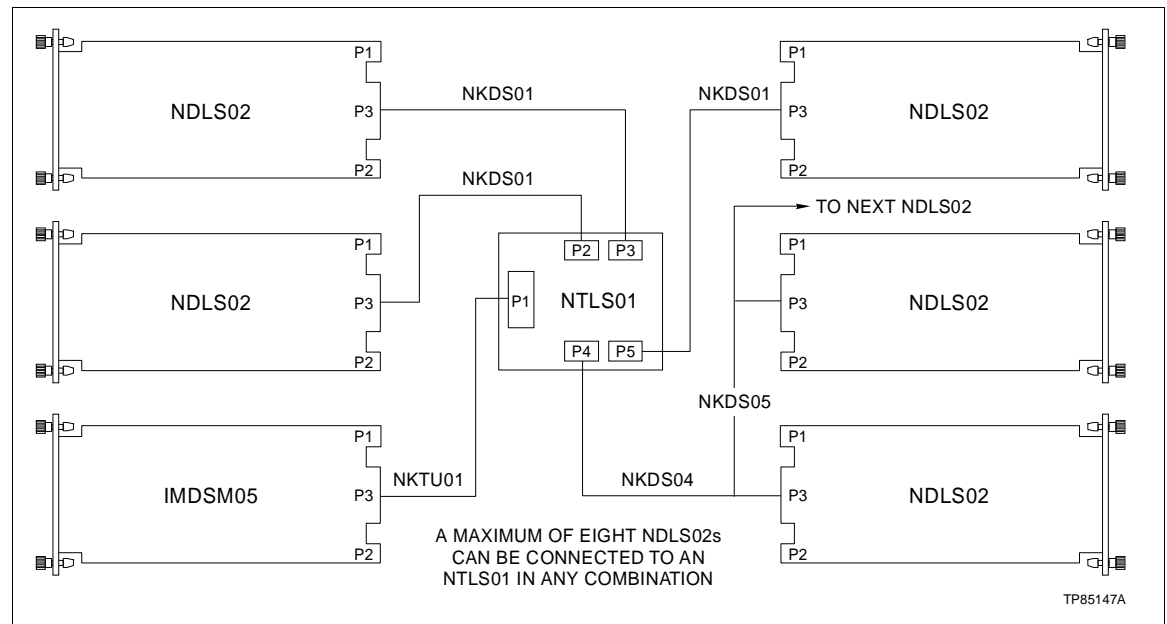

Figure C-1. Cable Connections For NTLS01

APPENDIX D - NIDI01 TERMINATION UNIT CONFIGURATION

INTRODUCTION

The NIDI01 interfaces the DSM to up to 16 field inputs such as switches, LEDs and solenoids. Change the wire jumpers to configure the NIDI01 for your application. The jumpers needed to select the PCU module are labeled on the NIDI01 circuit board.

INSTALLATION

Table D-1 shows the jumper configuration for a DSM05.

Table D-1. NIDI01 Configuration Summary

Application Signal Type	Connecting Cable	Dipshunt Configuration	No. of Outputs
24 VDC	NKTM01 OR NKTU02		16/0 OR 8/8

NOTE: The J1-J10 represents jumpers 1 through 10 on the NIDI01. A blank indicates an open jumper and a line indicates a jumper left intact.

After setting the switches on the DSM module and setting the jumpers on the termination unit, install the DSM, NIDI01 and cables as shown in Figure D-1. Figure D-2 shows the terminal assignments for P1 of NIDI01.

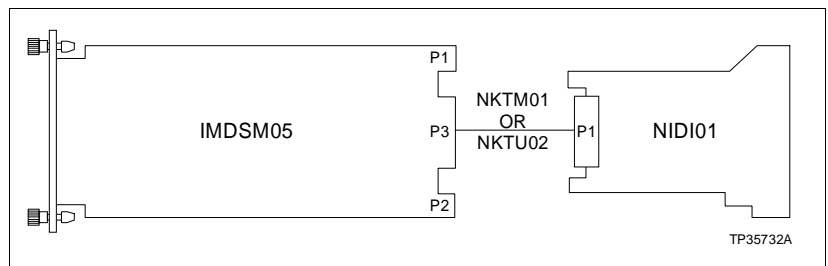

Figure D-1. Cable Connections For NIDI01

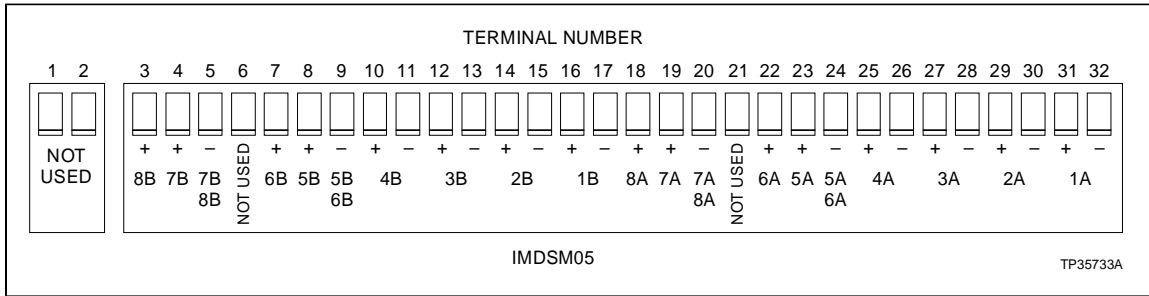

Figure D-2. Terminal Assignments NIDIO1

Visit *Elsag Bailey* on the World Wide Web at <http://www.bailey.com>

Our worldwide staff of professionals is ready to meet *your* needs for process automation.
For the location nearest you, please contact the appropriate regional office.

AMERICAS

29801 Euclid Avenue
Wickliffe, Ohio USA 44092
Telephone 1-216-585-8500
Telefax 1-216-585-8756

ASIA/PACIFIC

152 Beach Road
Gateway East #20-04
Singapore 189721
Telephone 65-391-0800
Telefax 65-292-9011

EUROPE, AFRICA, MIDDLE EAST

Via Puccini 2
16154 Genoa, Italy
Telephone 39-10-6582-943
Telefax 39-10-6582-941

GERMANY

Graefstrasse 97
D-60487 Frankfurt Main
Germany
Telephone 49-69-799-0
Telefax 49-69-799-2406